

Instrument Key

- ETC Source Four 50 • - 575w
- Altman 360Q 6x9 - 750w
- Altman 360Q 4.5x6 - 750w
- Altman 6" Fresnel - 750w
- Altman 8" Fresnel - 1000w
- PAR 64 MFL - 1000w
- PAR 64 WFL - 1000w
- PAR20 - 100w
- R40 6' 3 Circuit Strip - 150w
- 6.5" Barndoor
- Gobo Rotator

Label Legend

Template $\frac{1}{2}$ Color $\frac{z}{z}$
 Unit $\frac{1}{2}$ Channel $\frac{z}{z}$

+ indicates that there are two colors

Notes

- Horizontal dimensions are taken from the E-Pipe (CL)
- Vertical dimensions are taken from the 6-Pipe
- Split gels for rotator units should be created to match the image below, and dropped with the R310 on the bottom.

Templates

R77626 - Jagged Circles Rotating Gobo
 R77960 - Flames 4 Static Gobo

BU THEATRELAB

SCHOOL OF THEATRE

855 Commonwealth Avenue

Director: Lillian King
 Scenic Designer: Courtney Nelson
 Lighting Designer: Kayleigha Holten
 Assistant LD: Andy Auyong
 Master Electrician: Andy Auyong
 Drafted By: KEH

Date: 11/3/2012
 Revised: 12/8/2012
 Scale: 1/2" = 1' 0"

Plate #: **1** of 3

Vinegar Tom

Light Plot

House Floor Plate
 Note: NOT DRAWN IN PLACE
 See Sheet 2

Note: Dimensions are from bottom of pipe to c-clamp. Units are yolked straight out on pipe.

Note: Dimensions are from bottom of pipe to c-clamp. Units are yolked straight out on pipe.

SR Added Boom

SL Added Boom

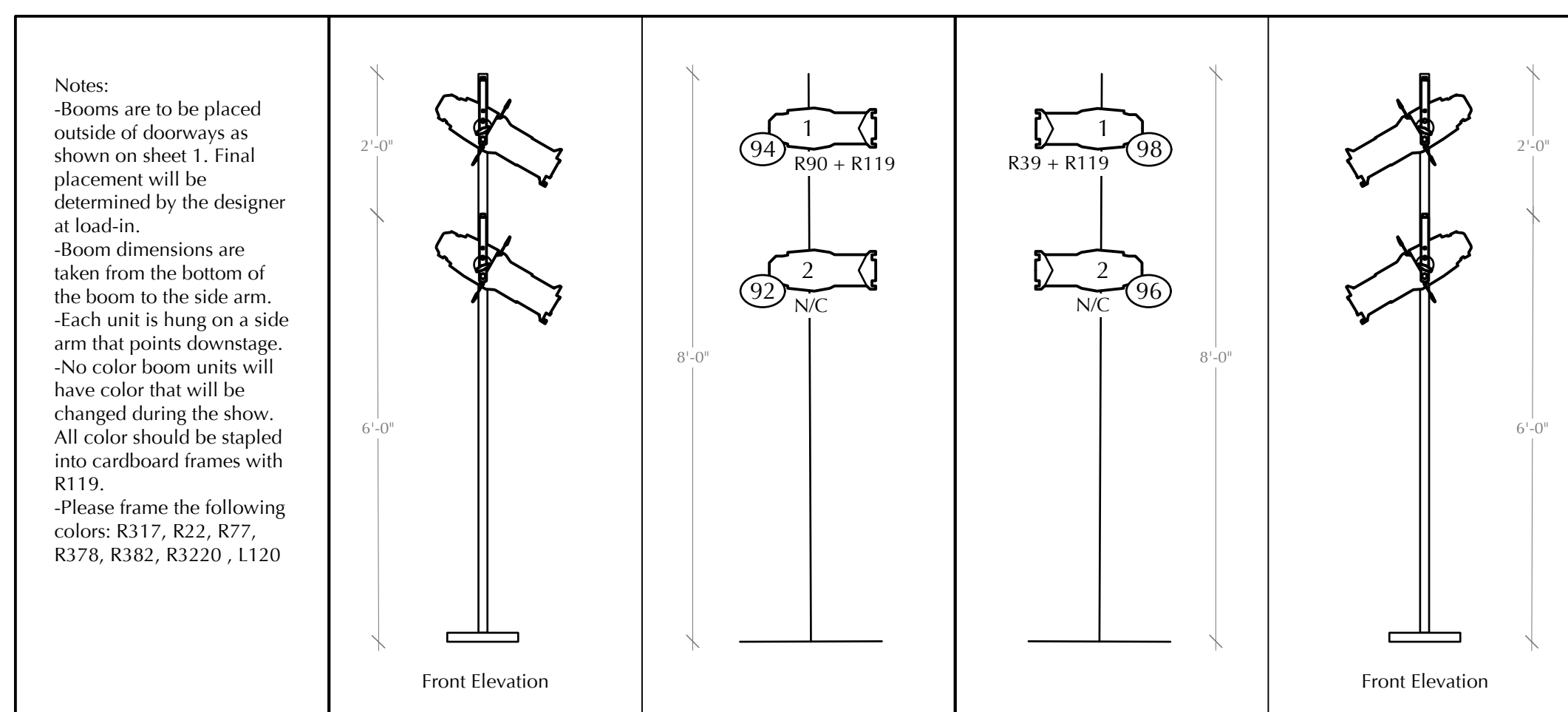

Goal Post

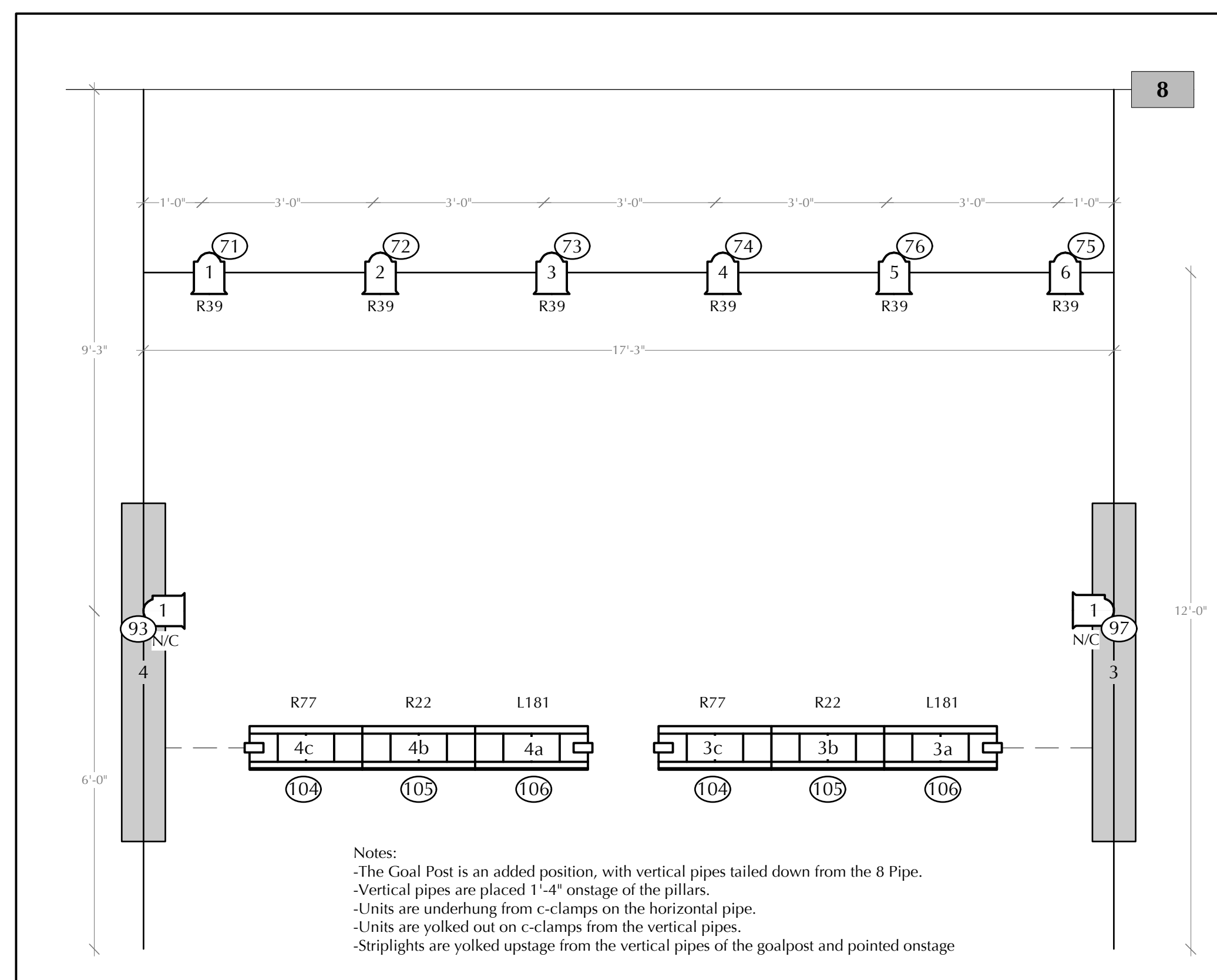

SR Floor Plates

SL Floor Plates

House Floor Plate

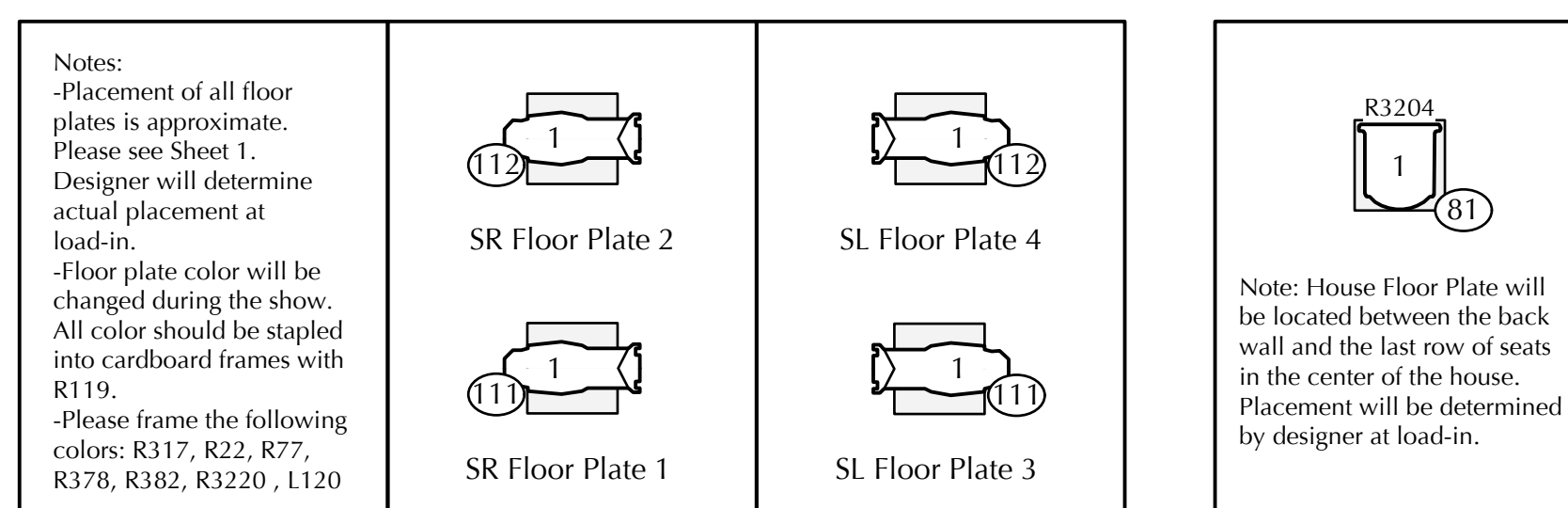

R40 Deck Strips

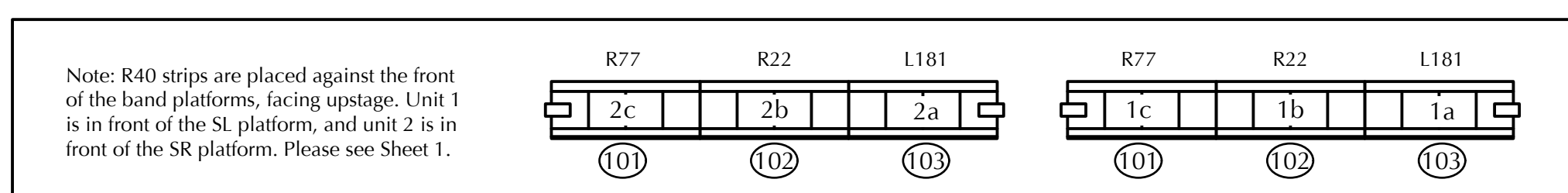

Band Birdie 2

Band Birdie 1

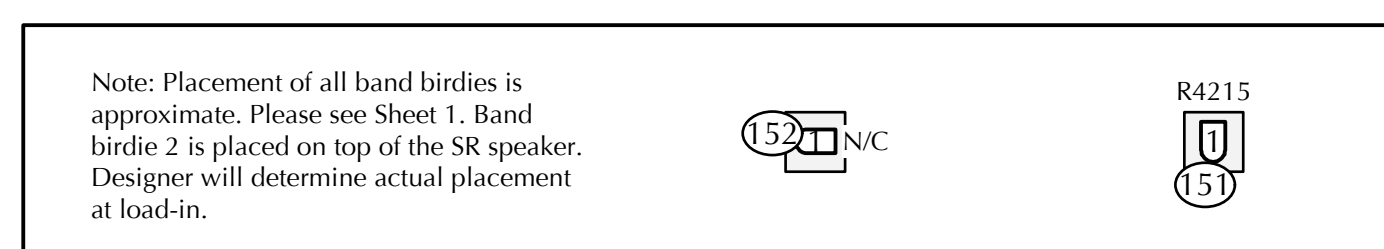

Instrument Key

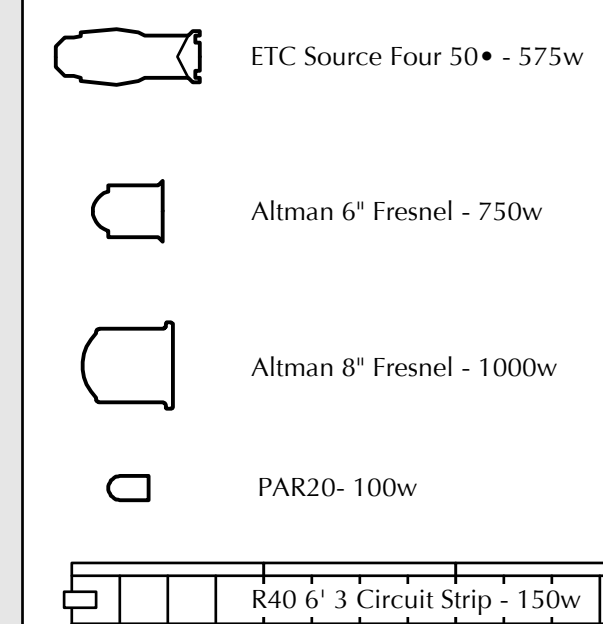

Label Legend

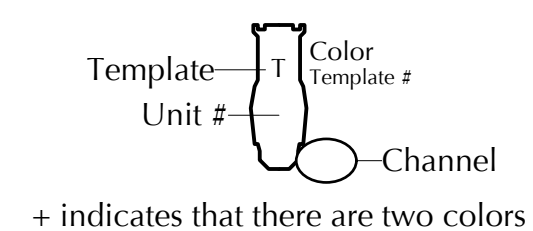

Notes

Templates

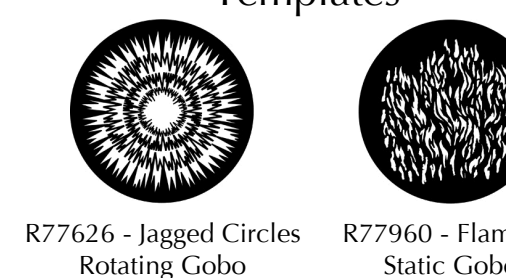

BU THEATRELAB
SCHOOL OF THEATRE

855 Commonwealth Avenue

Director: Lillian King
 Scenic Designer: Courtney Nelson
 Lighting Designer: Kayleigha Holten
 Assistant LD: Andy Auyong
 Master Electrician: Andy Auyong
 Drafted By: KEH

Date: 11/3/2012
 Revised: 12/8/2012
 Scale: 1/2" = 1' 0"

Plate #: **2** of 3

Vinegar Tom

Deck Plate

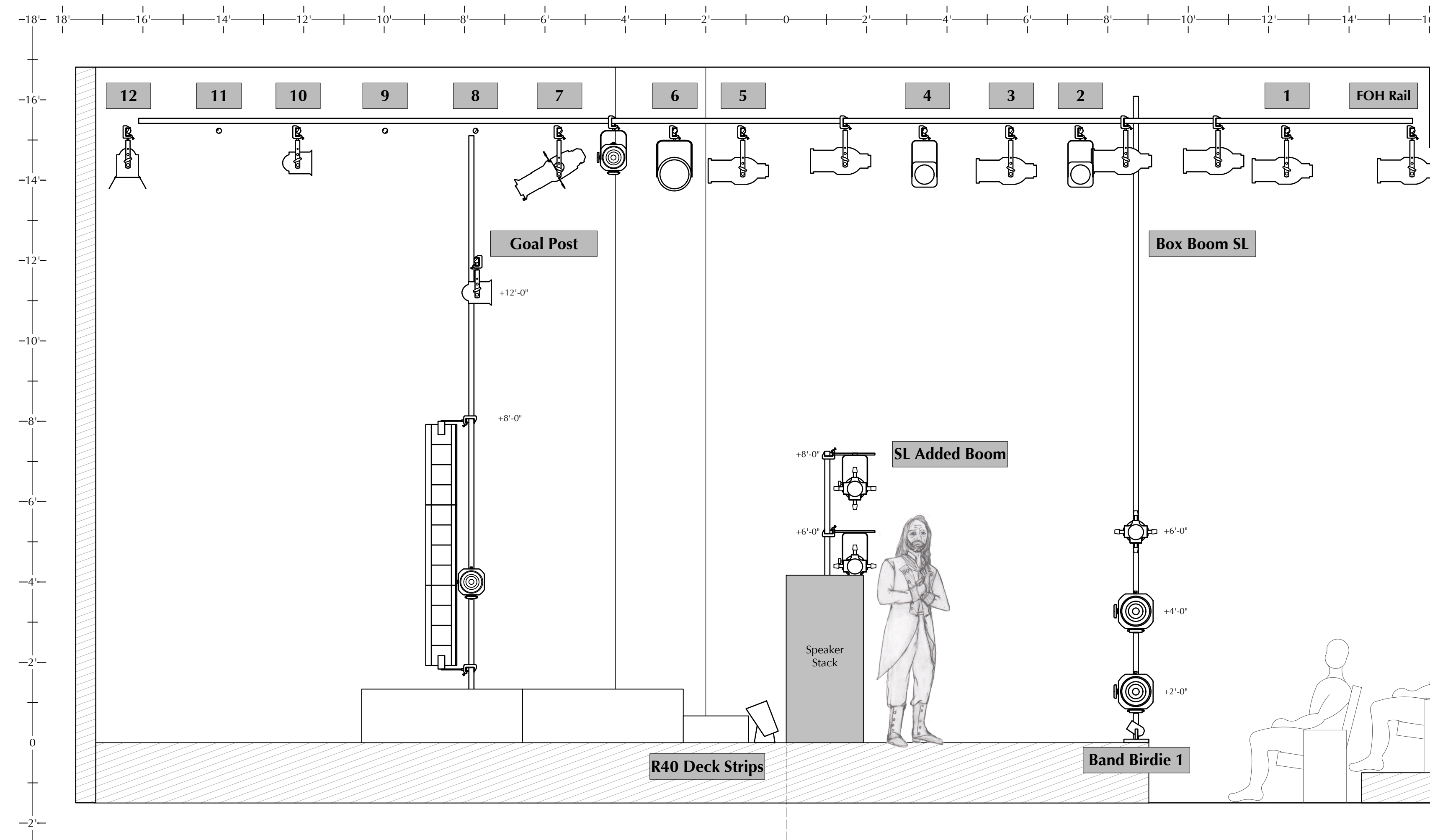

PLASTER

Instrument Key

- Source Four - 575w
Side View + Front View
- Altman 360Q- 750w
Side View + Front View
- PAR 64- 1000w
Front View
- Altman 6" Fresnel- 750w
Side View
- Altman 6" Fresnel- 750w
Front View
- Altman 8" Fresnel- 1000w
Front View
- PAR20- 100w
Section
- R40 6' 3 Circuit Strip- 150w
Section
- 6.5" Barndoor

Label Legend

Template $\frac{1}{z}$ Color
Unit # $\frac{1}{z}$ Channel

+ indicates that there are two colors

Notes

- Box Boom dimensions are from bottom of pipe to c-clamp
- Added Boom dimensions are from bottom of boom to side arm
- Goal Post dimensions are from stage deck to c-clamp

BU THEATRELAB
SCHOOL OF THEATRE

855 Commonwealth Avenue

Director: Lillian King lillian.king@gmail.com
 Scenic Designer: Courtney Nelson rebornscenic@gmail.com
 Lighting Designer: Kayleigha Hollen khollenke@gmail.com
 Assistant LD: Andy Auyong aauyong11@panabou.edu
 Master Electrician: Andy Auyong aauyong11@panabou.edu
 Drafted By: KEH

Date: 11/3/2012
 Revised: 12/8/2012
 Scale: 1/2" = 1' 0"

Plate #: **3** of 3

Vinegar Tom

Center Section Looking SL